

# VIKING

# TECHNICAL Practice

**TELECOM SOLUTIONS FOR THE 21ST CENTURY**

**K-1700 Series**  
**Handsfree Entry**  
**Phones with Keypads**

May 9, 2008

## Vandal Resistant Handsfree Entry Phones with Built-In Keypad

The **K-1700 Series** entry phones provide a tough and attractive handsfree phone for apartment, and residential door entry or applications requiring a vandal resistant speaker phone. The **K-1700 Series** entry phones are available in two attractive finishes: "brushed stainless steel" and "oil rubbed bronze".

When the "Call" button is pressed, the **K-1700-3** returns dial tone. The keypad may then be used to dial any number. If no Touch Tone is entered within 8 seconds, CPC is detected, a busy signal is detected, or the programmable maximum call time has elapsed, the **K-1700-3** will automatically disconnect. Alternatively, the **K-1700-3** may be disconnected by pressing the "Call" button again. The **K-1700-3** comes complete with a standard, flush mount, rough-in box. In addition, an optional **VE-6x7** weather resistant, surface mount box is available.

For outdoor or harsh environments, the **K-1700-3** is available with Enhanced Weather Protection (**EWP**). **EWP** products feature rubber gaskets and boots, closed cell foam gasketing, hand soldered silicon sealed connections, anti-corrosive gel filled butt connectors, as well as urethane encapsulated circuit boards with internally sealed, field-adjustable trim POTS and DIP switches.



**K-1700-3 "Brushed Stainless Steel"**  
(similar to brushed nickel)



**K-1700-3-BN "Oil Rubbed Bronze"**  
(satin dark brown powder paint with fine copper metallic)

## Features

- Vandal Resistant Features: 14 gauge, louvered, stainless steel faceplate with stainless steel speaker/mic screen, heavy duty metal keypad and "Call" button, scratch resistant powder coating (**K-1700-3-BN**) and hex drive mounting screws
- Available in 2 standard faceplate finishes: brushed stainless steel or oil rubbed bronze
- Optional Enhanced Weather Protection (**EWP**)
- Yellow "in use" LED
- Telephone line powered
- Volume adjustments for microphone and speaker
- Advanced call progress detection: disconnects on busy signal, return to dial tone, CPC, reorder tone, maximum call time out and 40 second silence time out
- Selectable auto-answer feature for monitoring
- Selectable push button disconnect
- Zinc plated steel rough-in box with (2) 3/4" conduit knockouts
- Optional **VE-6x7** Surface Mount Box available
- Microphone and speaker volume controls
- Selectable VOX switching speed
- **K-1700-3-EWP** conforms to NEMA requirements

## Applications

- Apartment entry phone when used with the **K-1900-3** Apartment Entry Dialer (**Fax Back # 312**) or **C-3000** Apartment Entry Controller (**Fax Back # 162**)
- Residential gate or door entry phone when used with the **C-2000A** Door Entry Controller (**Fax Back # 156**)
- Courtesy and customer assistance phone
- Automated teller (ATM) phone
- Security or emergency phone
- Hot-Line phone when used with the **K-1900-5** Hot-Line Dialer (**Fax Back # 317**) *Note: When installing a line powered phone on a low voltage and/or low loop current phone system extension, a **TBB-1** Talk Battery Booster may be required (**Fax Back # 630**).*
- Kiosk phone with (100 number speed dialing) when used with the **K-1900-9** Multi-Number Dialer (**Fax Back # 321**)

## Specifications

**Power:** Telephone line powered 20V DC/20mA minimum  
**Dimensions:** Overall: 140mm x 165mm x 66mm (5.5" x 6.5" x 2.6"), Rough-in box: 114mm x 140mm x 64mm (4.5" x 5.5" x 2.5")  
**Shipping Weight:** 1.6 kg (3.5 lbs)  
**Environmental:** -29°C to 54°C (-20°F to 130°F)  
**Humidity - K-1700-3:** 5% to 95% non-condensing  
**Humidity - K-1700-3-EWP:** Up to 100% condensing  
**Speaker Volume:** Approximately 70 db maximum @1m  
**Connections:** Standard - (1) two-position terminal block, **EWP** - Gel-filled tip and ring connectors  
**CPC Disconnect Time:** 500ms minimum  
**REN #:** 0.5 A

Phone...715.386.8861

<http://www.vikingelectronics.com>

## IF YOU HAVE A PROBLEM WITH A VIKING PRODUCT, PLEASE CONTACT: VIKING TECHNICAL SUPPORT AT (715) 386-8666

Our Technical Support Department is available for assistance Monday 8am - 4pm and Tuesday through Friday 8am - 5pm central time. So that we can give you better service, before you call please:

1. Know the model number, the serial number and what software version you have (see serial label).
2. Have your Technical Practice in front of you.
3. It is best if you are on site.

### RETURNING PRODUCT FOR REPAIR

The following procedure is for equipment that needs repair:

1. Customer must contact Viking's Technical Support Department at 715-386-8666 to obtain a Return Authorization (RA) number. The customer MUST have a complete description of the problem, with all pertinent information regarding the defect, such as options set, conditions, symptoms, methods to duplicate problem, frequency of failure, etc.
2. Packing: Return equipment in original box or in proper packing so that damage will not occur while in transit. Static sensitive equipment such as a circuit board should be in an anti-static bag, sandwiched between foam and individually boxed. All equipment should be wrapped to avoid packing material lodging in or sticking to the equipment. Include ALL parts of the equipment. C.O.D. or freight collect shipments cannot be accepted. Ship cartons prepaid to:  
**Viking Electronics, 1531 Industrial Street, Hudson, WI 54016**
3. Return shipping address: Be sure to include your return shipping address inside the box. We cannot ship to a PO Box.
4. RA number on carton: In large printing, write the R.A. number on the outside of each carton being returned.

### RETURNING PRODUCT FOR EXCHANGE

The following procedure is for equipment that has failed out-of-box (within 10 days of purchase):

1. Customer MUST contact Viking's Technical Support at 715-386-8666 to determine possible causes for the problem. The customer MUST be able to step through recommended tests for diagnosis.
2. If the Technical Support Product Specialist determines that the equipment is defective based on the customer's input and troubleshooting, a Return Authorization (R.A.) number will be issued. This number is valid for fourteen (14) calendar days from the date of issue.
3. After obtaining the R.A. number, return the approved equipment to your distributor, referencing the R.A. number. Your distributor will then replace the product over the counter at no charge. The distributor will then return the product to Viking using the same R.A. number.
4. **The distributor will NOT exchange this product without first obtaining the R.A. number from you. If you haven't followed the steps listed in 1, 2 and 3, be aware that you will have to pay a restocking charge.**

### LIMITED WARRANTY

Viking warrants its products to be free from defects in the workmanship or materials, under normal use and service, for a period of one year from the date of purchase from any authorized Viking distributor or 18 months from the date manufactured, whichever ever is greater. If at any time during the warranty period, the product is deemed defective or malfunctions, return the product to Viking Electronics, Inc., 1531 Industrial Street, Hudson, WI., 54016. Customer must contact Viking's Technical Support Department at 715-386-8666 to obtain a Return Authorization (R.A.) number.

This warranty does not cover any damage to the product due to lightning, over voltage, under voltage, accident, misuse, abuse, negligence or any damage caused by use of the product by the purchaser or others.

**NO OTHER WARRANTIES. VIKING MAKES NO WARRANTIES RELATING TO ITS PRODUCTS OTHER THAN AS DESCRIBED ABOVE AND DISCLAIMS ANY EXPRESS OR IMPLIED WARRANTIES OR MERCHANTABILITY OR FITNESS FOR ANY PARTICULAR PURPOSE.**

**EXCLUSION OF CONSEQUENTIAL DAMAGES. VIKING SHALL NOT, UNDER ANY CIRCUMSTANCES, BE LIABLE TO PURCHASER, OR ANY OTHER PARTY, FOR CONSEQUENTIAL, INCIDENTAL, SPECIAL OR EXEMPLARY DAMAGES ARISING OUT OF OR RELATED TO THE SALE OR USE OF THE PRODUCT SOLD HEREUNDER.**

**EXCLUSIVE REMEDY AND LIMITATION OF LIABILITY. WHETHER IN AN ACTION BASED ON CONTRACT, TORT (INCLUDING NEGLIGENCE OR STRICT LIABILITY) OR ANY OTHER LEGAL THEORY, ANY LIABILITY OF VIKING SHALL BE LIMITED TO REPAIR OR REPLACEMENT OF THE PRODUCT, OR AT VIKING'S OPTION, REFUND OF THE PURCHASE PRICE AS THE EXCLUSIVE REMEDY AND ANY LIABILITY OF VIKING SHALL BE SO LIMITED.**

**IT IS EXPRESSLY UNDERSTOOD AND AGREED THAT EACH AND EVERY PROVISION OF THIS AGREEMENT WHICH PROVIDES FOR DISCLAIMER OF WARRANTIES, EXCLUSION OF CONSEQUENTIAL DAMAGES, AND EXCLUSIVE REMEDY AND LIMITATION OF LIABILITY, ARE SEVERABLE FROM ANY OTHER PROVISION AND EACH PROVISION IS A SEPARABLE AND INDEPENDENT ELEMENT OF RISK ALLOCATION AND IS INTENDED TO BE ENFORCED AS SUCH.**

### FCC REQUIREMENTS

This equipment complies with Part 68 of the FCC rules and the requirements adopted by the ACTA. On the side of this equipment is a label that contains, among other information, a product identifier in the format US:AAAEQ##TXXXX. If requested, this number must be provided to the telephone company.

The REN is used to determine the number of devices that may be connected to a telephone line. Excessive REN's on a telephone line may result in the devices not ringing in response to an incoming call. In most but not all areas, the sum of the REN's should not exceed five (5.0) To be certain of the number of devices that may be connected to a line, as determined by the total REN's, contact the local telephone company. For products approved after July 23, 2001, the REN for this product is part of the product identifier that has the format US:AAAEQ##TXXXX. The digits represented by ## are the REN without a decimal point (e.g., 03 is a REN of 0.3). For earlier products, the REN is separately shown on the label.

The plug used to connect this equipment to the premises wiring and telephone network must comply with the applicable FCC Part 68 rules and requirements adopted by the ACTA. If your home has specially wired alarm equipment connected to the telephone line, ensure the installation of this K-1700 Series does not disable your alarm equipment. If you have questions about what will disable alarm equipment, consult your telephone company or a qualified installer.

If the K-1700 Series causes harm to the telephone network, the telephone company will notify you in advance that temporary discontinuance of service may be required. But if advance notice isn't practical, the telephone company will notify the customer as soon as possible. Also, you will be advised of your right to file a complaint with the FCC if you believe it is necessary.

The telephone company may make changes in its facilities, equipment, operations, or procedures that could affect the operation of the equipment. If this happens, the telephone company will provide advance notice in order for you to make

the necessary modifications to maintain uninterrupted service.

If trouble is experienced with the K-1700 Series, for repair or warranty information, please contact:

**Viking Electronics, Inc., 1531 Industrial Street, Hudson, WI 54016 (715) 386-8666**

If the equipment is causing harm to the telephone network, the telephone company may request that you disconnect the equipment until the problem is resolved.

Connection to Party Line Service is subject to State Tariffs. Contact the state public utility commission, public service commission or corporation commission for information.

#### WHEN PROGRAMMING EMERGENCY NUMBERS AND (OR) MAKING TEST CALLS TO EMERGENCY NUMBERS:

Remain on the line and briefly explain to the dispatcher the reason for the call. Perform such activities in the off-peak hours, such as early morning or late evenings.

It is recommended that the customer install an AC surge arrester in the AC outlet to which this device is connected. This is to avoid damaging the equipment caused by local lightning strikes and other electrical surges.

### PART 15 LIMITATIONS

This equipment has been tested and found to comply with the limits for a Class A digital device, pursuant to Part 15 of the FCC Rules. These limits are designed to provide reasonable protection against harmful interference when the equipment is operated in a commercial environment. This equipment generates, uses, and can radiate radio frequency energy and, if not installed and used in accordance with the instruction manual, may cause harmful interference to radio communications. Operation of this equipment in a residential area is likely to cause harmful interference in which case the user will be required to correct the interference at his own expense.

# Installation

## A. Mounting

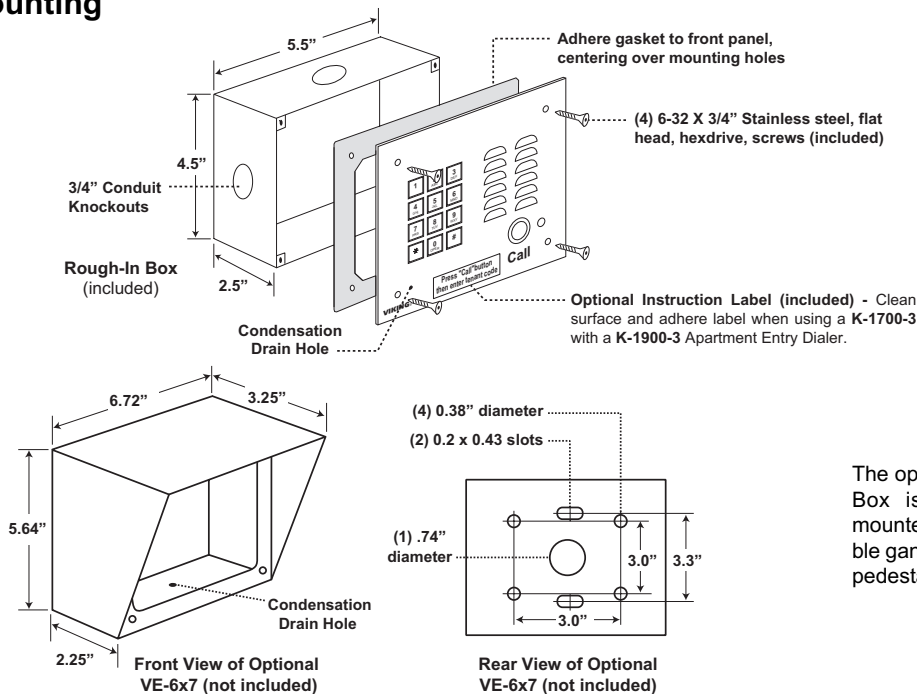

The optional **VE-6x7** Surface Mount Box is designed to be surface mounted to a single gang box, double gang box or **VE-GNP** gooseneck pedestal (right).

## B. Wiring

\* **Note:** When installing a line powered phone on a low voltage and/or low loop current phone system extension, a **TBB-1** Talk Battery Booster may be required.

\*\*\* **Note:** To increase surge protection, loosen the PCB mounting screw labeled ⊕ (as shown right) and fasten a wire with spade terminal (included) from the mounting screw to Earth Ground (grounding rod, water pipe, etc.)

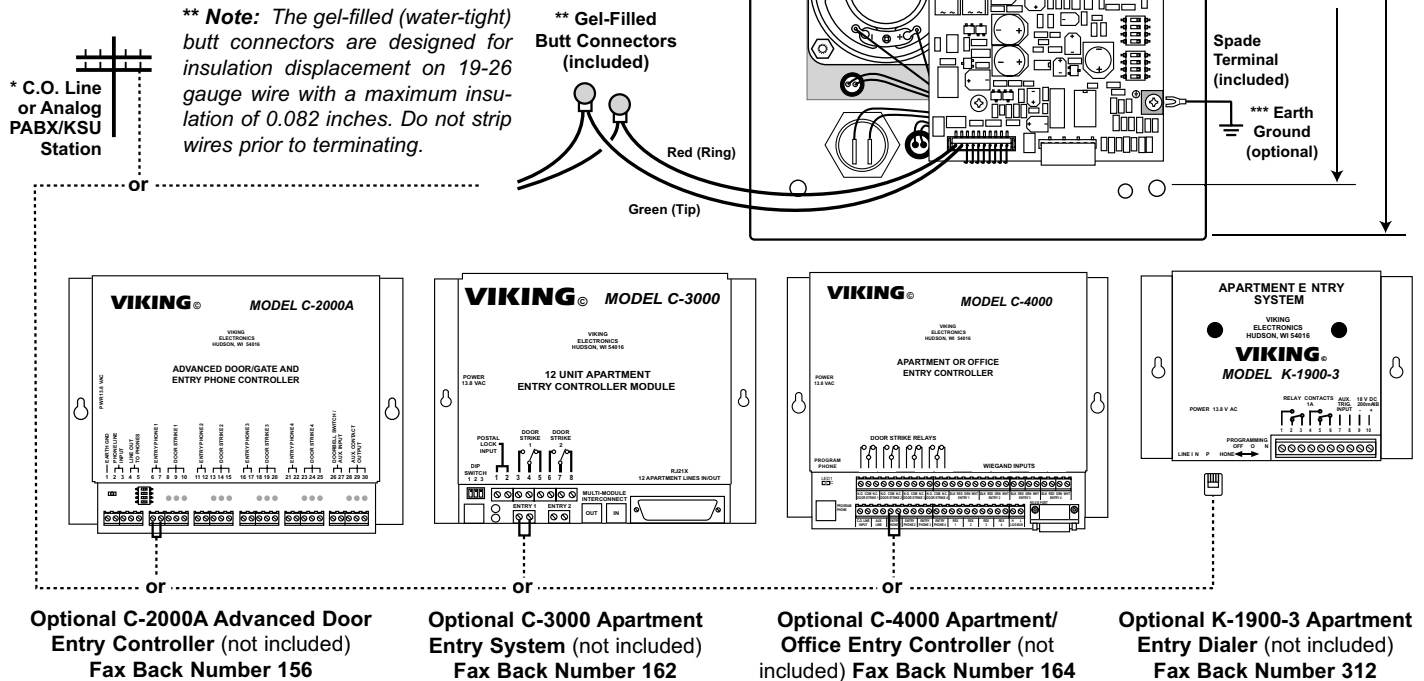

# Programming

## A. DIP Switch Programming / Speaker and Microphone Adjustments

Switch 1	Switch 2	Maximum Call Time
OFF	OFF	Disabled (default)
ON	OFF	1 minute
OFF	ON	3 minutes
ON	ON	9 minutes

Switch 3	Disconnect on Dial Tone
OFF	Off
ON	On (default)

Switch 4	VOX Switching Speed
OFF	Fast, 0.2 seconds (default)
ON	Slow, 0.7 seconds

Switch 5	Switch 6	Audio Detection
ON	ON	Normal audio detection
OFF	OFF	Increase audio detect sensitivity for low level lines. Useful in applications in which voice or busy signals have trouble breaking over the speaker.

Switch 7	Auto Answer Feature
OFF	Automatic answer disabled
ON	Automatic answer enabled (default)

Switch 8	Push Button Feature
OFF	Connects calls only
ON	Connects/disconnects calls (default)

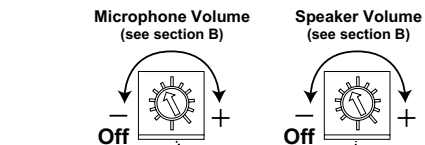

Rear View of the K-1700-3

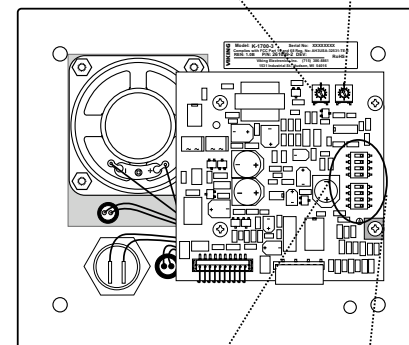

DIP Switches (shown in default positions)

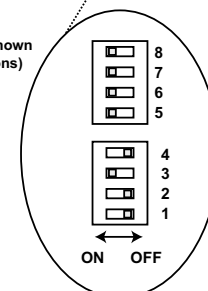

## B. Volume Adjustments

1. **Microphone:** Certain noisy locations (background traffic, machinery or wind) may cause one way talk path (only microphone audio is heard). In this case, the microphone volume may need to be decreased as shown above.
2. **Speaker:** To increase, decrease or turn off the speaker (for monitoring purposes only), adjust the speaker volume control as shown above.

## C. Auto-Answer Feature (DIP Switch 7)

With DIP switch 7 in the "ON" position (default), the **K-1700-3** will automatically answer the line during the first incoming ring. This feature is useful for monitoring entrances. In the "OFF" position, the **K-1700-3** will not automatically answer incoming calls.

## D. Push Button Hang Up (DIP Switch 8)

With DIP switch 8 in the "ON" position (default), the "Call" button alternately connects and disconnects calls. In the "OFF" position, the "Call" button is only used to connect and the **K-1700-3** must rely on call progress (busy, return to dial tone, silence time-out, or maximum call time) for an automatic disconnect.

## E. VOX (Talk/Listen) Switching Speed (DIP Switch 4)

With DIP switch 4 in the "OFF" position (default), the VOX switching speed (delay time between talk and listen mode) is set to fast (0.2 seconds). In the "ON" position, it is set to slow (0.7 seconds).

## F. Advanced Call Progress Detection

The **K-1700-3** will output 3 beeps and automatically hang-up after detecting any of the following: busy signal (standard or fast/reorder), CPC (short break in line current when called party hangs up), return to dial tone (with DIP switch 3 ON), maximum call time (if enabled) or 40 second silence time out.

# Applications

## A. C-2000A Advanced Door/Gate and Entry Phone Controller



 Need More Information on the C-2000A?  
Call (715) 386-4345 and select 156.

The **C-2000A** allows up to 4 entry phones to call into your existing residential or business phones or phone system. Tenants may answer the call, converse with the visitor and activate a contact closure to control electronic gates or door strikes.

The **C-2000A** provides "Caller ID," "Call Waiting ID" and "Call Waiting" tone when the phone line is in use. Tenants may gain entry at each gate by entering a Touch Tone keyless entry code.

Tenants may call out to each entry phone for monitoring purposes. An auxiliary input is also available for connecting a common garage door opener/receiver and auxiliary keyless entry keypads.

## B. K-1900-3 Apartment/Office Entry Dialer



 Need More Information on the K-1900-3?  
Call (715) 386-4345 and select 312.

The **K-1900-3** converts any Touch Tone phone into a multi-number auto dialer that will store up to 150 telephone numbers in non-volatile E<sup>2</sup> memory. Use with Viking's **K-1700-3** or **K-1900-8** phones to provide vandal resistant handsfree or handset communication.

When a call initiated by the **K-1900-3** is answered by an apartment or business tenant, a built-in contact closure may be activated to control an electric gate or door strike. Up to 150 keyless entry codes may also be programmed, providing tenants with keyless entry. The **K-1900-3** can be programmed locally or remotely using a standard Touch Tone phone. The **K-1900-3** has built-in user dialing restriction to help prevent unauthorized calls and toll fraud.

**Product Support Line...715.386.8666**

**Fax Back Line...715.386.4345**

Due to the dynamic nature of the product design, the information contained in this document is subject to change without notice. Viking Electronics, and its affiliates and/or subsidiaries assume no responsibility for errors and omissions contained in this information. Revisions of this document or new editions of it may be issued to incorporate such changes.